

MINI 35 Digital

MINI 35 Digital[®]

Image Converter

User Manual

Model "Oszi" 400 Series



Congratulations!

You now have the power to produce the look and feel of 35mm film using a MiniDV camcorder. The P+S Technik Mini35Digital image converter is designed for use on the Canon XL1 and Canon XL1S camcorders as well as the Sony DSR-PD150/ DCR-VX2000/ DCR-VX1000 cameras, Panasonic AG-DVX100 and coming soon, the JVC JY HD10. The unit is optimized for 35mm lenses with large rear optical elements, such as Cooke S4 Primes, Zeiss Ultra Primes and Zeiss Super Speeds. Zeiss Distagons with focal lengths over 40mm will also work.

Improved features of the “Oszi” 400 series

- Improved image screen – Finer grain pattern for better imaging
- New oscillating movement – The elliptical motion of the PRO35 has been incorporated...no more center spot!
- Adjustable speed control - Allows greater control over the speed setting of the moving focus screen (we recommend the setting be kept between 3 and 4).
- Improved optics for Sony connecting kit
- New unified body construction



World Wide Technical Support

P+S Technik GmbH

Email info@pstechnik.de

Phone +49 89 45 09 82 30

North America

ZGC., Inc.

Email sales@zgc.com

Phone +1 973-335-4460

printed January 04

Contents

Congratulations.....	3
Contents	5
Delivery Content	6
Connecting Kits.....	7
Preparation	8
General Description	9
With CANON XL1 / XL1S.....	13
With SONY DSR-PD150 / DCR-VX1000 / DCR-VX2000	21
With PANASONIC AG-DVX100.....	29
Maintenance	37
Optional Accessories & Mounts	37
Frequently Asked Questions.....	38
Dealers	44
Technical Data.....	45
Technical Support.....	46

Delivery Content - Basic Module

- 1 – Mini35Digital Image converter, fitted with an interchangeable lens mount of your choice (PL, Panavision, Nikon, et al.)
- 2 – Hand Grips (top and side)
- 1 – Support Interface with Integrated Shoulder Set and 15mm LWS systems

The support interface provides 1/4" and 3/8" attachment points allowing the use of all industry standard tripods, bridge plates and other support systems e.g. Steadicam. The 15mm LWS system accepts all film style accessories including follow focus and matte boxes. An ordered connecting kit is already mounted.



- Connecting Kits

- 1 - Relay Lens with protective cap
- 1 - Mounting Plate
- 1 - Battery Plate with power cable
- 1 - Remote Control Cable
- 1 – Hex screwdriver set and screws
- 1 - Color Viewfinder Holder
(Canon Connecting Kit)

A Connecting Kit ordered with the basic module is already mounted when delivered. Camera connecting kits must be purchased separately for each brand and are available for the following Mini Digital Video Cameras.

Canon XL1/XL1S –
Sony DSR-PD150 /DCR-VX1000 /DCR-VX2000 –
Panasonic AG-DVX100 –



Preparation

Avoid Murphy's Law!!

Assemble the Mini35Digital image converter on your camcorder **BEFORE** the first day of your production. After attaching the unit to your camera according to the steps outlined below, be sure to check each of your lenses, f-stop combinations and shutter adjustments for compatibility. We recommend at least a half, if not full, day of testing before production. You will need a more robust film lighting "package" rather than the typical video lighting "kit" for optimal image capture. The Mini35Digital is not a magical device, time and effort will be needed to obtain the desired images at first, but will become second nature as your productions progress.

*****USAGE NOTE*****

The Mini35Digital creates a lively cine-like image with an artificial film grain pattern. How much the film grain pattern is adequate for you depends on your preference. To adjust the visibility of the pattern use the 8-step speed control wheel (J) and the T-stops. To optimize the effect, the taking lens should be as wide open as possible: Use the iris on the relay lens of the XL1(S) Mini35, and ND filters for bright outdoor shots. With the Panasonic and Sony Mini35, exposure control is done on the camera lens with the camera set in full manual mode.

Items needed before you begin:

- A 2.5mm hex wrench (delivery content)
- A 35mm format film lens for testing and
- A high quality test chart, such as the Putora 7A9
- A control monitor is recommended.

Munich / New York, December 2003

P+S Technik GmbH



General Description

Pos.	Description	Comment
A	Hook	For Tape Measure
B	LWS System	Light Weight Support System Prepared for 15mm rods
C	Wheel	Clamping screw for LWS
D	Intermediate Flange	Takes the Interchangeable Mount Interchangeable Mount connects to Lens

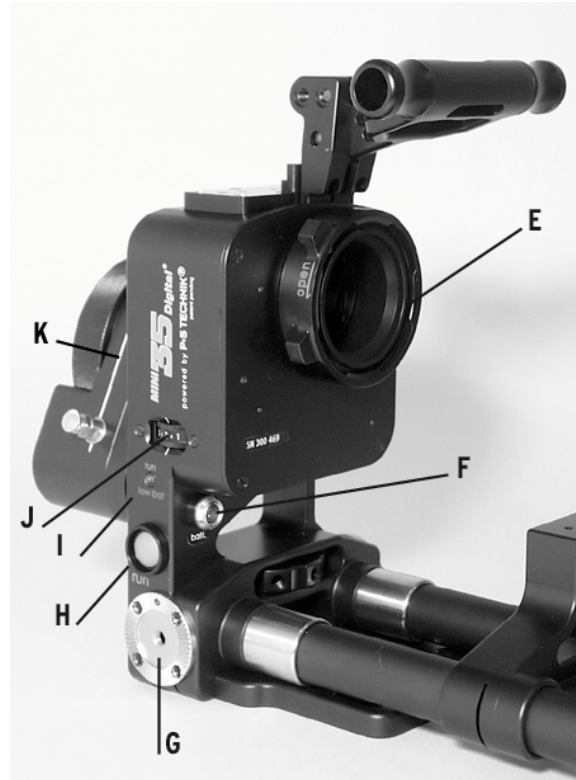

Pos.	Description		Comment
E	Bayonet Mount	Takes Relay Lens	Relay Lens connects to Camera
F	BATT. Input Connector	Battery Cable	Pin 1 – Bat - Pin 2 – Bat. +
G	Rose Wheel		
H	RUN	GREEN button	Manual RUN / STOP
I	Control LED		
	RUN	GREEN →	Runs with chosen speed
	LOW BAT	RED (low power) →	Acceptable speed Prepare new battery
		Blinking light →	Below minimum speed, change bat.
J	Speed Control	Wheel 8 steps	Controls oscillating movement
K	Focal Plane	White Engraving	

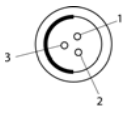
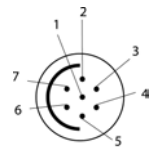

Pos.	Description		Comment
L	REMOTE input	3 Pin Fischer female socket 	Pin 1 – GND Pin 2 – N.C. Pin 3 – VTR
M	INPUT (for LANC cable)	7 Pin Fischer female socket 	Pin 1 – not connected Pin 2 – VTR trigger Pin 3 – Bat + Pin 4 – U Bat ex Pin 5 – not connected Pin 6 – Bat - Pin 7 – RET
N	Control LED RUN LOW BAT	GREEN → RED (low power) → Blinking light →	Good speed control Acceptable speed Below minimum speed

Power Connection

Connect the cable from the battery plate with the battery input (F) and load battery in the plate. The Connecting Kit uses the same battery type as the camera.

LANC & Remote Control with the Mini35Digital

The Mini35 can also be controlled via a remote control unit. Use the LANC cable to connect the Mini35 via the INPUT connection (M) with the camera. Then connect the Mini35 via the REMOTE connection (L) with the remote control unit.

7-pin LANC Cable

Red connector – Canon & Sony

Black connector - Panasonic

Canon XL1/XL1S

Sony DSR-PD150 / DCR-VX1000 / DCR VX2000

The Mini35 can now be controlled:

- Independent & manually by the Mini35 RUN button or
- Both manually via the camera START button or
- Together via a Remote Control System

Panasonic AG-DVX100

The camera has no LANC interface and can only receive commands. So both can be controlled

- Independent & manually by the Mini35 RUN button or
- Together via a Remote Control System

CANON XL1 / XL1s

Follow the steps below to properly attach the Mini35Digital image converter to your Canon XL1 / XL1S with lightweight support

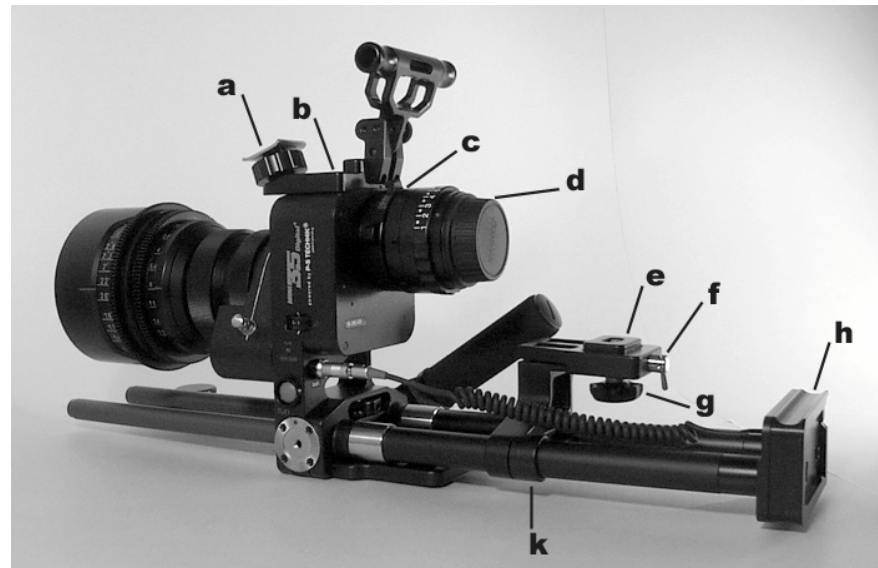

- a** – Viewfinder Holder
- b** – Top Cover
- c** - Lock Ring
- d** - Relay Lens
- e** - Spring loaded pad
- f** – Support release
Lever
- g** - Camera Screw
- h** - Battery Holder
- k** - Bottom Screws



Steps	Instructions	Explanatory Notes
1	Make sure the camera is turned off.	
2	Remove the relay lens from the Mini35: a. Locate the lock ring (c). b. Rotate the lock ring (c) counter clockwise.	The relay is attached to the rear of the Mini35 via a bayonet type mount. The lock ring (c) is the ring located in the front of the relay lens, nearest to the body of the Mini35 (photo page 11).
3	Attach the relay lens onto the camera: The relay lens attaches like any other XL mounted lens. →	a. Line up the red dots b. Engage the lens in the mount c. Rotate the lens until the lock clicks in place.

4 Prepare the Mini35:

- a. Release the two screws (k) on the bottom of the camera support, and slide the support toward the rear battery holder. The first time a camera has to be installed you will find it easier to start by sliding the camera support out of the way.
- b. Release the lever (f), push the pad (e) down and lock it in that position by tightening lever (f). The camera support platform has a spring-loaded pad in the center that adjusts for the height of the camera. The knob with a lever (f), at the back of the camera platform, locks the spring-loaded pad in place. By releasing that knob, the spring will push the pad to its highest position making the mounting of the camera difficult.

5 Mount the relay lens (now attached to the camera) onto the Mini35Digital image converter:

Engage the relay into the back port of the Mini35 and secure it in place with the lock ring (c).→

- a. Open the lock ring (c).
- b. Line up the relay lens into the port holding the camera by its top handle. Make sure the locating pin is fully engaged.
- c. Close the lock ring (c) clockwise to secure the relay lens.

Note: Be sure the camera does not accidentally disengage.

6 Attach the camera support:

Slide the camera support bracket under the camera and attach the knob (g) to the bottom of the camera:

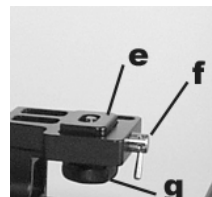

Lock the lever (f) at the back of the camera support and lock the screws at the bottom of the camera support.

- a. The big knurled knob (g) through the camera platform has to line up with the 1/4" threaded hole on the camera bottom.
 - b. Start engaging the thread of the knob in the thread of the camera but do not tighten it yet.
 - c. Release the lever (f) at the back of the platform to allow the spring-loaded pad (e) to come in contact with the base of the camera.
- Finish tightening the knob (g) at the bottom of the platform.



Follow the steps below to test the image once the Mini35 is attached to the camera:

Steps	Instructions	Explanatory Notes
1	Install a 35mm film lens in the mount.	
2	Turn on the camera in the fully manual position.→	The message "CHECK THE LENS" will be displayed in the viewfinder for several seconds, then the image should appear with the word "LENS" blinking. *) If the image is too dark: a. Open the iris on the film lens. b. Open the iris on the relay lens.
3	Focus the 35mm film lens on an object.	The image should be sharp in the viewfinder and on the field monitor.

*) The Canon XL1 and XL1S will electronically recognize only lenses made by Canon to work with these cameras. Accordingly, you will see a lens warning light in the viewfinder when using the Mini35Digital Image converter. This is normal and will have no effect on the footage you shoot. With the XL1 camera, you cannot eliminate the lens warning light from blinking in the viewfinder, but it is possible to remove it from an external monitor using the "ON SCREEN" key of the remote control. With the XL1S camera, you can control the lens warning light via the "EFV DISPLAY ON/OFF" key on the left side of the camera.

If the image does not appear as sharp as expected, a back focus adjustment is necessary. Before changing the back focus please note that the image photographed by the camera is generated on the focus screen inside the Mini35. This focus screen lowers the contrast of the image similar to the effect of a low contrast filter. This is desirable since it removes some of the electronic detail artifact typical in a DV image, even though at a quick glance the image may appear less sharp than the one recorded by the unfiltered original lens.

Test if the back focus is properly adjusted

Place the camera with the Mini35Digital image converter mounted with a 35mm lens, in front of a high quality test definition chart, such as the Putora 7A9 chart. The iris on the relay should be fully opened. The film lens should be focused by eye to the point of best resolution (highest number of circles visible on the Putora chart). Without changing anything else, close the iris of the relay a couple of stops. The resolution should not visibly increase. If it does, the back focus of the relay needs to be adjusted. Follow the steps below to adjust the relay back focus.

Follow the steps below to adjust the relay back focus.

Steps	Instructions	Explanatory Notes
1	Release the hex screw k (1.5mm) by about a half a turn. Now the ring is free for adjustment:	
2	Leave the Iris on the relay lens fully open and adjust the back focus ring until you have achieved the sharpest image.	
3	Check that the film lens is at the best focus before you check the back focus a second time.	You will need a good quality monitor to accurately judge the sharpness.
4	Once satisfied with the image, lock the hex screw to secure this adjustment and double check the image.	By using a Putora 7A9 chart you will be able to see the moiré effect of the test circles visible through the relatively low definition of the viewfinder.

SONY DSR-PD150 / DCR-VX1000 / DCR-VX2000

Follow the steps below to properly attach the Mini35Digital Image converter to your Sony DSR-PD150 / DCR-VX1000 /DCR-VX2000 with lightweight support

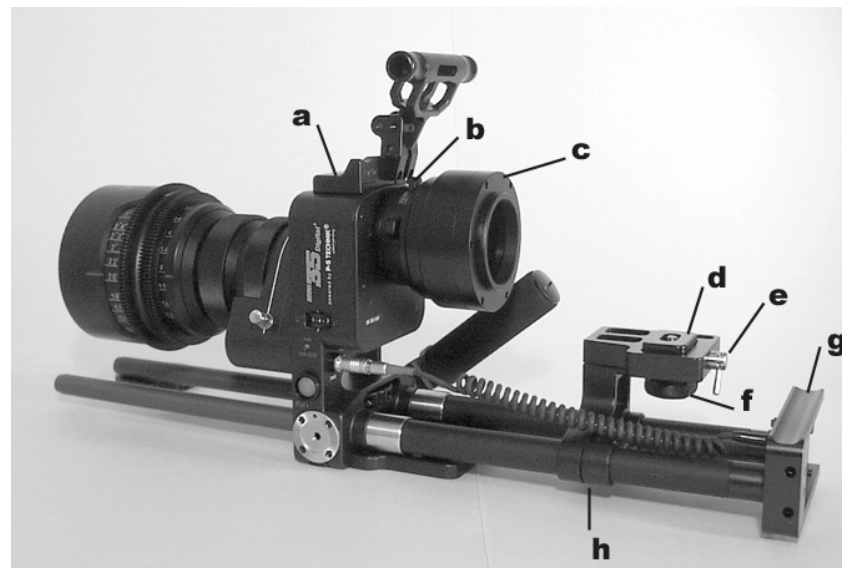

- a** - Top Cover
- b** - Lock Ring
- c** - Relay Lens
- d** - Spring loaded Pad
- e** - Support release
Lever
- f** - Camera Screw
- g** - Battery Holder
- h** - Bottom Screws

**S
O
N
Y**

Steps	Instructions	Explanatory Notes
1	Make sure the camera is turned off.	
2	Remove the relay lens from the Mini35: a. Locate the lock ring (b). b. Rotate the lock ring (b) counter clockwise.	The relay is attached to the rear of the Mini35 via a bayonet type mount. The lock ring (b) is the ring located in the front of the relay lens, nearest to the body of the Mini35.
3	Attach the relay lens onto the camera:	Remove all filters, sunshades, adapter rings, etc. before attaching the relay lens directly onto the camera front lens

4 Prepare the Mini35:

a. Release the two screws (h) on the bottom of the camera support, and slide the support toward the rear battery holder.

The first time a camera has to be installed you will find it easier to start by sliding the camera support out of the way.

b. Release the knob (e), push the pad (d) down and lock it in that position by tightening knob (e).

The camera support platform has a spring-loaded pad in the center that adjusts for the height of the camera. The knob with a lever (e), at the back of the camera platform, locks the spring-loaded pad in place. By releasing that knob the spring will push the pad to its highest position making the mounting of the camera difficult

5 Mount the relay lens (now attached to the camera) onto the Mini35Digital image converter:

Before the 1st attachment, the bayonet mount of the relay lens has to be adjusted:

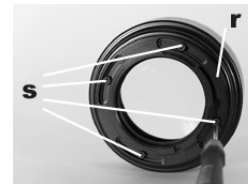

Engage the relay into the back port of the Mini35 and secure it in place with the lock ring (b).

- a. Open the lock ring (b)
- b. Slightly release the 4 screws (s) in front of the relay lens. The bayonet ring (r) must be moveable.
- c. Line up the relay lens into the port holding the camera by its top handle. Make sure the locating pin is fully engaged. Close lock ring.
- d. Bring the camera carefully into a standard vertical position. Then remove camera without losing this position.
- e. Lock the 4 screws in the relay front and re-connect relay lens to the adapter port
- f. Close the lock ring (b) clockwise to secure the relay lens.

Note: Be sure the camera cannot disengage accidentally.

6 Attach the camera support:

Slide the camera support bracket under the camera and attach the knob (f) to the bottom of the camera:

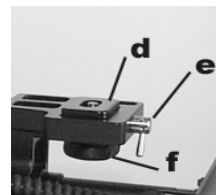

Lock the lever (e) at the back of the camera support and lock the screws at the bottom of the camera support

- a. The big knurled knob (f) through the camera platform has to line up with the 1/4" threaded hole on the camera bottom.
- b. Start engaging the thread of the knob in the thread of the camera but do not tighten it yet.
- c. Release the lever (e) at the back of the platform to allow the spring-loaded pad (d) to come in contact with the base of the camera.
- d. Finish tightening the knob (f) at the bottom of the platform.

Follow the steps below to test the image once the Mini35 is attached to the camera:

Steps	Instructions	Explanatory Notes
1	Install a 35mm film lens in the mount.	
2	Turn on the camera in the fully manual position:	a. Turn off the AutoFocus and Zoom function b. Focus camera lens on the ground glass inside the converter If the image is too dark: c. Open the iris on the film lens. d. Open the iris on the camera lens.
3	Focus the 35mm film lens on an object.	The image should be sharp in the viewfinder and on the field monitor.

If the image does not appear as sharp as expected, there is a back focus adjustment on the relay. But before we change the setting of the back focus it is important to realize that the image photographed by the camera is generated on the focus screen inside the Mini35. This focus screen lowers the contrast of the image somewhat in a way similar to the effect of a low contrast filter. This is desirable since it removes some of the electronic detail artifact typical in a DV image, even though at a quick glance the image may appear less sharp than the one recorded by the unfiltered original lens.

Test if the back focus is properly adjusted

Place the camera with the Mini35Digital image converter mounted with a 35mm lens, in front of a high quality test definition chart, such as the Putora 7A9 chart. The iris on the relay should be fully open. The film lens should be focused by eye to the point of best resolution (highest number of circles visible on the Putora chart). Without changing anything else, close the iris of the relay a couple of stops. The resolution should not visibly increase. If it does, the back focus of the relay needs to be adjusted. Follow the steps below to adjust the relay back focus.

Follow the steps below to adjust the relay back focus.

Steps	Instructions	Explanatory Notes
1	Leave the Iris on the camera lens fully open and adjust the camera back focus until you have achieved the sharpest image.	
2	Check that the film lens is at the best focus before you check the back focus a second time.	You will need a good quality monitor to accurately judge the sharpness of the image. By using a Putora 7A9 chart you will be able to see the moiré effect of the test circles visible through the relatively low definition of the viewfinder.
3	Lock the back focus and double check the image.	

PANASONIC DVX100

Follow the steps below to properly attach the Mini35Digital image converter to your Panasonic AG-DVX100 camera with lightweight support

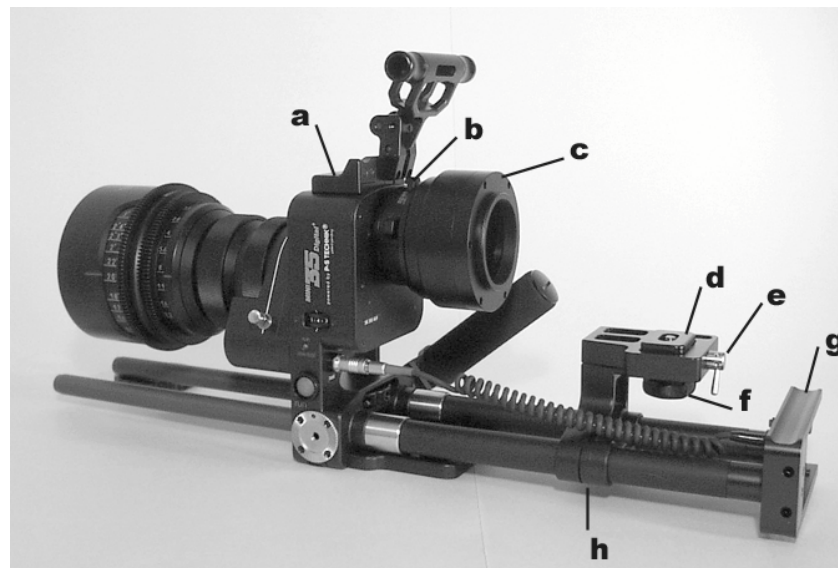

- a** - Top Cover
- b** - Lock Ring
- c** - Relay Lens
- d** - Spring loaded Pad
- e** - Support release
Lever
- f** - Camera Screw
- g** - Battery Holder
- h** - Bottom Screws

Steps	Instructions	Explanatory Notes
1	Make sure the camera is turned off.	
2	Remove the relay lens from the Mini35: a. Locate the lock ring (b). b. Rotate the lock ring (b) counter clockwise.	<p>The relay is attached to the rear of the Mini35 via a bayonet type mount.</p> <p>The lock ring (b) is the ring located in the front of the relay lens, nearest to the body of the Mini35.</p>
3	Attach the relay lens onto the camera:	<p>a. Remove all filters, sunshades, adapter rings, etc. before attaching the relay lens directly onto the camera front lens</p> <p>b. Eventually you need a rubber pad to grip the protective cap, recessed deeply in the hood</p>

4 Prepare the Mini35:

- a. Release the two screws (h) on the bottom of the camera support, and slide the support toward the rear battery holder.

- b. Release the knob (e), push the pad (d) down and lock it in that position by tightening knob (e).

The first time a camera has to be installed you will find it easier to start by sliding the camera support out of the way.

The camera support platform has a spring-loaded pad in the center that adjusts for the height of the camera. The knob with a lever (e), at the back of the camera platform, locks the spring-loaded pad in place. By releasing that knob the spring will push the pad to its highest position making the mounting of the camera difficult

5 Mount the relay lens (now attached to the camera) onto the Mini35Digital image converter:

Before the 1st attachment, the bayonet mount of the relay lens has to be adjusted:



- a. Open the lock ring (b)
- b. Slightly release the 4 screws (s) in front of the relay lens. The bayonet ring (r) must be moveable.
- c. Line up the relay lens into the port holding the camera by its top handle. Make sure the locating pin is fully engaged. Close lock ring.
- d. Bring the camera carefully into a standard vertical position. Then remove camera without losing this position.
- e. Lock the 4 screws in the relay front and re-connect relay lens to the adapter port
- f. Close the lock ring (b) clockwise to secure the relay lens.

Engage the relay into the back port of the Mini35 and secure it in place with the lock ring (b).

Note: Be sure the camera cannot disengage accidentally.

6 Attach the camera support:

Slide the camera support bracket under the camera and attach the knob (f) to the bottom of the camera:

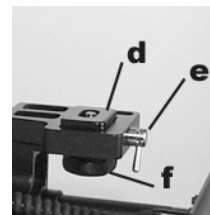

Lock the lever-knob (e) at the back of the camera support and lock the screws at the bottom of the camera support

- a. The big knurled knob (f) through the camera platform has to line up with the 1/4" threaded hole on the camera bottom.
- b. Start engaging the thread of the knob in the thread of the camera but do not tighten it yet.
- c. Release the lever-knob (e) at the back of the platform to allow the spring-loaded pad (d) to come in contact with the base of the camera.
- d. Finish tightening the knob (f) at the bottom of the platform.

Follow the steps below to test the image once the Mini35 is attached to the camera:

Steps	Instructions	Explanatory Notes
1	Install a 35mm film lens in the mount.	
2	Turn on the camera in the fully manual position.	<ul style="list-style-type: none">• Turn off the AutoFocus and Zoom function• Focus camera lens on the ground glass inside the converter <p>If the image is too dark:</p> <ul style="list-style-type: none">a. Open the iris on the film lens.b. Open the iris on the camera lens.
3	Focus the 35mm film lens on an object.	The image should be sharp in the viewfinder and on the field monitor.

If the image does not appear as sharp as expected, there is a back focus adjustment on the relay. But before we change the setting of the back focus it is important to realize that the image photographed by the camera is generated on the focus screen inside the Mini35. This focus screen lowers the contrast of the image somewhat in a way similar to the effect of a low contrast filter. This is desirable since it removes some of the electronic detail artifact typical in a DV image, even though at a quick glance the image may appear less sharp than the one recorded by the unfiltered original lens.

Test if the back focus is properly adjusted

Place the camera with the Mini35Digital image converter mounted with a 35mm lens, in front of a high quality test definition chart, such as the Putora 7A9 chart. The iris on the relay should be fully opened. The film lens should be focused by eye to the point of best resolution (highest number of circles visible on the Putora chart). Without changing anything else, close the iris of the relay a couple of stops. The resolution should not visibly increase. If it does, the back focus of the relay needs to be adjusted. See the following steps to adjust the relay back focus.

Follow the steps below to adjust the relay back focus.

Steps	Instructions	Explanatory Notes
1	Leave the Iris on the camera lens fully open and adjust the camera back focus until you have achieved the sharpest image.	
2	Check that the film lens is at the best focus before you check the back focus a second time.	You will need a good quality monitor to accurately judge the sharpness of the image. By using a Putora 7A9 chart you will be able to see the moiré effect of the test circles visible through the relatively low definition of the viewfinder.
3	Lock the back focus and double check the image.	

Maintenance

The prism should be cleaned periodically depending on environmental conditions, Always use a professional lens cleaning solution.

Optional Accessories for the Mini35Digital

- Adapter kit for Canon B&W viewfinder
- Additional side handgrips
- Additional camera connecting kits
- Custom lens mounts and support interfaces
- Top handle for use with EasyRig or Marzpak

Available Lens Mounts

- PL-Mount
- Pana-Mount
- Nikon
- Canon EF
- Zeiss Contax
- Leica R + M

Contact you local P+S Technik dealer for prices and availability.

Frequently Asked Questions

Q: Will the Angle of View of the lens I'm using be affected?

A: No, the Angle of View of the lens on the Mini35 will be similar to the Angle of View as seen in the Academy 35mm frame. Reason: The image the Mini35Digital creates is not projected directly onto the camera's CCDs, but is first resolved onto the focus screen. The camera then captures this image, with all of its filmic characteristics, including Depth of Field.

Q: My image is vignetted (dark frame around image). Why?

A: Make sure that your matte box and any equipment in front of the lens does not cause the vignetting.

Some old lens designs with small rear lenses do not work properly with the Mini35, because the diameter of the last lens is too small. This is concerning the Cooke Series II & III and Zeiss Distagons below 40mm. The 25-250mm zooms by Angenieux as well as Cooke are both tight, but work properly. We did not test all still photography lenses, but due to the bigger image size (Still - 24x36mm vs. Cine – 18x24mm) no vignetting is expected.

Q: Do I have to send my camera to P+S Technik to do any mechanical or electronic changes before I can use the Mini35Digital image converter?

A: No. No modifications to the camera are necessary.

Q: Does the Mini35Digital require a power supply?

A: Yes. You will need a battery to run the motor of the Mini35Digital. Each camera connecting kit includes a battery mount specific to the brand of camera so no new batteries or chargers are needed, simply the batteries you already have for your system; one for the camera and one for the Mini35Digital.

Q: What will the image look like as compared to a digital video look?

A: A textbook-perfect digital video image is uniformly sharp, background and foreground. The professional 35mm motion picture film “look” is sharp but less starkly so. Capturing the image in 35mm format with a 35mm lens also allows you to

capture gradations of focus (depth of field) like the human eye sees images on a image plane.

Tip For the best effect when composing a shot, aim for out-of-focus objects in both the foreground and background.

Q: How can I avoid having the grain of the projection glass showing up on the tape?

A: Don't stop the taking lens down above 4 - 5.6. Regulate the light as much as possible with the relay lens only (XL1(s) version). Use neutral density filters when there is too much light.

Q: Are there differences between the Canon XL1 and XL1S when using the Mini35Digital image converter?

A: With the XL1S, you can use the slow shutter without Canon lenses. Also, the XL1S chip is more sensitive to light – an advantage when using the Mini35Digital image converter.

Q: Do I need any additional editing equipment?

A: No. The Mini35 does not affect the format of the camera. The images are still being recorded in the 1/3" MiniDV format for use in your current post chain.

Q: How much light is lost?

A: -In general, 1 Stop.

Q: Where can I get more information on the Mini35 or connect with other users of the adapter?

A: General information is available from www.pstechnik.de. Questions can be forwarded to info@pstechnik.de. DVInfo.net (www.dvinfo.net) hosts a P+S Technik forum (<http://www.dvinfo.net/conf/forumdisplay.php?s=&forumid=58>) where many users post questions, insight into, and experiences with the device. Mizell Wilson of ZGC, Inc. is the official monitor of this forum and is happy to answer any questions that the community cannot.

Q: I want to include a credit for P+S and the Mini35 in my production; do you have a preferred format of your logo or artwork available?

A: We appreciate this very much. Logos and artwork are available for download at www.pstechnik.de.

Q: Is there any prejudice towards the MiniDV format?

A: Yes. Even though MiniDV is a SMPTE standard “broadcast quality” format, many television stations and other venues will not accept MiniDV tapes and/or assume that the production value of MiniDV is low. We recommend burning your footage to DVD or transferring it to a higher format (BetaSP, DigiBeta, DVCPRO50) for presentation to these types of outlets.

Q: I’ve finished my movie and want the world to see it; can you help me distribute it?

A: **Our tip** Check out www.customflix.com for the latest in independent distribution of your film.

Q: I am using an XL1(S) and want a progressive look, but I don’t like Frame mode, are there any options?

A: While we have not tested it ourselves, we have heard very good things about DVFilmMaker from www.dvfilm.com.

Q: I am using a PAL XL1(S) for the increased resolution and color, but plan to distribute in NTSC. Is there a simple process for converting from one format to another?

A: In the past this would have required you to go to a professional transfer house, and for the best results, you still might want to consider this. With the same caveat as above, check out Atlantis from www.dvfilm.com.

Q: Do I need a support for my prime lenses?

What about cine zooms?

A: Most cine and still primes will not need any support. Larger still primes and zooms, typically special-use telephoto lenses, will need additional support. All cine zooms will require the use of an external bridge plate system for support.

Q: What are the major differences between using cine lenses and still lenses?

A: As far as optical quality, the SLR still lenses are on a par with cine primes. The major difference is the ergonomics of the lenses. Since they were not designed to capture moving images, the focus and zoom movements may not be as smooth as the movement on a cine lens. In addition, older zoom lenses will not hold their focus while

zooming in and out and functionally become variable primes. We do have reports that the newest SLR zooms will hold focus throughout the range. Make sure to test the individual lens before production.

Q: Can I use 16mm lenses?

A: No, this is not possible. The 16mm lenses project an image (10,4x7,4mm) not half as big as the 35mm image (18x24mm) the Mini35 is working with. Strong vignetting will appear.

You can only use 35mm cine and still photography lenses.

Q: Can I use Nikon AF lenses?

A: Yes. The physical mount of the AF lenses is the same as the standard (MF) lenses and focus, iris, and zoom control can be set to

manual. There are reports that these lenses are not as smooth in their movement in manual mode as compared to the MF lenses but will otherwise function normally. The Mini35 does not provide any type of electronic lens control.

Q: Will the Mini35 control the iris of my Canon EF lenses?

A: No. The Mini35 does not provide any type of electronic lens control. EF lenses are wide open by default, which means there is no problem using them with the Mini35; you will simply have no way to stop down the lens for Depth of Field control.

Q: Can I use commercially available anamorphic adapters with the Mini35?

A: No. The Mini35 connects directly to the cameras and does not allow for the use of any of the prosumer anamorphic attachments. There are two methods for shooting 16x9. The first is to shoot 4:3, composing for 16x9 and then masking in post. The XL1S provides on-screen guides to assist in this process. The second is to use the in-camera 16x9 feature. To achieve a 2.4:1 “scope” look you are able to use anamorphic cine lenses from companies such as Panavision and Hawk. Most NLE systems will allow for an anamorphic unsqueeze during capture. The image will appear squeezed in the viewfinder or field monitor unless you have a monitor that can perform an unsqueeze or you use an inline unsqueeze device similar to the Transvideo format converter.

Dealers

France

EMIT Modern Images Techniques
Tel: +33-1-48 13 90 10
Email: emit@wanadoo.fr

Germany

P+S Technik GmbH
Tel: +49-89-45 09 82 30
Email: info@pstechnik.de

Great Britain

OpTex International
Tel: +44-20-84 41 21 99
Email: simon@optexint.com

Holland

Holland Equipment B.V.
Tel: +31-20-694 35 75
Email: sales@hollandequipment.nl

Sweden

Svensk Film & Ljusteknik AB
Tel: +46-8-54 55 18 20
Email: Stig@sfl.se

Spain

Video Cine Import S.A.
Tel: +349-663 64 66
Email: vci@terra.es

North American Distributor

ZGC, Inc.
Tel: +1 973-335-4460
Email: sales@zgc.com

Peru, Equador, Bolivia, Brasil

Moviecenter
Tel. : 00511-221 40 58

Australia

LEMAC Film & Video Equipment
Tel: +61-2-94 38 44 88
Email: jbowring@ozemail.com.au

GUS

Dedo Weigert Film GmbH
Tel: +49-89-35 61 61 11
Email: mwarnck@dedoweigertfilm.de

China

SUI SUN TRADING CO., LTD.
Email: pspro35@yahoo.com.tw

Japan

SHOTOKU CORP.
Tel: +81-44-833 33 51
Email: ebimoto@shotoku.co.jp

Korea

SAMA Electronics Corp.
Tel: +82-2-34 72 05 65
Email: inn@samakorea.com

Singapore, Thailand, Malaysia,

Philippines, Indonesia

Transmarco H. Warta Pte Ltd
Email: thwarta.general@transmarco234.com

Sri Lanka

Maclear Film Equipment Services
Tel: +9412-58 55 73
Email: maclear@slt.lk

Taiwan

Viewpoint Image Assembling
Tel: +8862-23 03 78 99
Email: vpia@ms64.hinet.net

Technical Data

	Canon XL1(S)	Sony DSR-PD150 / DCR-VX1000 / DCR-VX2000	Panasonic AG- DVX100	JVC HD10U
Mini35Digital Camera Mount (converter to camera)	Canon XL1 Mount	Screw Mount	Screw Mount	Coming Soon
Mini35Digital Lens Mount (converter to lens)	Mount by Choice			
Tuning for Shooting Sensor	Back Focus Relay Lens	Back Focus - Camera Lens		
Length of Mini35Digital unit	345 mm	345 mm	345 mm	
Weight	2.85 kg 6.27 lbs.	3.0 kg 6.6 lbs	3.0 kg 6.6 lbs	
Frame position	Upright, Emulsion Side Up			
Pro35Digital's Iris Diaphragm (behind lens)	Built-in for Light Reduction (No effect on depth-of-focus)			
Current consumption	300mA / 7.2 V			
Power supply	Adapter Battery connected via 2-pin cable			
Image Target Frequency Eccentric	Variable speed - 8 steps			



World Wide Technical Support

P+S Technik GmbH

Email info@pstechnik.de

Phone +49 89 45 09 82 30

North America

ZGC., Inc.

Email sales@zgc.com

Phone +1 973-335-4460

printed January 04